



**Brown Sheep  
Company, Inc.**

PATTERN  
**1201**

# Isabella Jacket

*Designed exclusively for Brown Sheep Company by Diane Zangl*

**SKILL LEVEL** ~ Intermediate

## SIZE

Woman's small (medium, large, extra-large) Instructions are given for smallest size, with larger sizes in parentheses. When only one number is given, it applies to all sizes.

## FINISHED MEASUREMENTS

**Chest:** 38 (42, 46, 50)"

**Total length (at center back with border):** 20 (20½, 22, 22½)

## MATERIALS

- Brown Sheep *Serendipity Tweed*, 60% cotton/40% wool (100g/210 yds per skein): 4 (4, 5, 6) skeins #ST52 African Violet (MC)
- Brown Sheep *Cotton Fleece*, 80% cotton/20% wool (100g/215 yds per skein): 1 skein #CW850 Berry (CC)
- Size 6 (4mm) 36" circular needles (2) **or size needed to obtain gauge**
- Stitch holders and markers

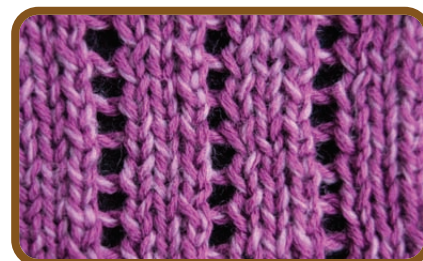

## GAUGE

19 sts x 25 rows = 4" in pattern

To save time and ensure proper fit, take time to check gauge.

## DESIGNER NOTES

- Jacket is worked in one piece to the underarms, where it is divided for fronts and back.
- The open ribbed pattern reverses position at the center back, giving gentle shaping to the lower edge. Slipped stitches accentuate the change in direction.
- There is a round neckline and modified set-in sleeves.
- Bound-off Braid in a contrasting color trims all edges.
- Work sleeve first and use it as your gauge swatch

## STITCH GLOSSARY

**M1 (Make 1):** Make a backwards loop and place on RH needle.

## SLEEVE

With MC, cast on 61 (65, 69, 73) sts. Purl 1 row. Mark center st. **Row 1:** K2, \*yo, k2tog, k2; rep from \* to marked st, sl center st k-wise, k2, \*\*ssk, yo, k2; rep from \*\* to end of row. **Row 2:** Purl. Rep Rows 1-2, inc 1 st each end every 6 (6, 8, 8)th row 4 times – 69 (73, 77, 81) sts. Work added sts into pat. Work even until sleeve measures 5 (5, 6, 6)" from beg. Mark each end st for underarm. Work even for 2½ (3, 3½, 4¼)" more above underarm marker. Bind off.

Sew sleeve seam from lower edge to underarm markers.

**Bound-off Braid Edging (worked in rnds):** With RS facing, join CC at sleeve seam. Pick up and knit 1 st in each cast-on st. Bind off loosely k-wise. \*Pick up and knit 1 st in each purl bump behind bound-off row (see diagram). Bind off loosely k-wise. Rep from \* once.

## BODY

With MC, cast on 181 (201, 221, 241) sts. Purl 1 row. Mark center st. **Row 1:** K2, \*yo, k2tog, k2; rep from \* to marked st, sl center st k-wise, k2, \*\*ssk, yo, k2; rep from \*\* to end of row. **Row 2:** Purl. Rep Rows 1-2 until body measures 10 (10, 11, 11)" from beg, ending with a WS row.

### Divide for fronts and back

Place markers 45 (50, 55, 60) sts in from each end. You will have 91 (101, 111, 121) sts marked for the back and 45 (50, 55, 60) sts for each front.



**Brown Sheep Company, Inc. • 100662 County Road 16 • Mitchell, NE 69357  
800-826-9136 • FAX 308-635-2143 • www.brownsheep.com**

**Next row (RS):** Work in established pat to 12 (15, 17, 20) sts before first marker and place sts just worked on holder for right front. Bind off next 24 (30, 34, 40) sts for right underarm. Work to 12 (15, 17, 20) sts before next marker, place remaining 57 (65, 72, 80) sts on second holder for left underarm and front.

## BACK

Work even in established pat on back sts only until armhole measures 7½ (8, 8½, 9)" above bound-off underarm sts, ending with a WS row.

### Shape back neck and shoulders

Mark center 25 (27, 29, 31) sts. Work to first marker, join second ball of yarn and bind off marked sts, work to end of row. Working on both sides of neck with separate balls of yarn, dec 1 st at each neck edge every row 3 times, **at the same time** bind off at each arm edge 6 (6, 7, 7) sts twice, then 6 (7, 7, 8) sts once.

## RIGHT FRONT

Sl sts from first holder to ndl. With WS facing, join MC at underarm. Purl 1 row. Work even in established pat until armhole measures 5 (5½, 6, 6½)" above bound-off underarm sts, ending with a WS row.

### Shape neck

Bind off at neck edge 6 (6, 7, 7) sts once, 4 sts once, then 2 sts once. Dec 1 st every RS row 3 (4, 4, 5) times – 18 (19, 21, 22) sts. Work even until armhole measures same as for back above bound-off underarm sts, ending with a RS row. Bind off at arm edge 6 (6, 7, 7) sts twice, then 6 (7, 7, 8) sts once.

## LEFT FRONT

Sl sts from second holder to ndl. With RS facing, join MC at underarm. Bind off 24 (30, 34, 40) sts, work in established pat to end of row. Work even in established pat until armhole measures 5 (5½, 6, 6½)" above bound-off underarm sts, ending with a RS row.

### Shape neck

Bind off at neck edge 6 (6, 7, 7) sts once, 4 sts once, then 2 sts once. Dec 1 st every RS row 3 (4, 4, 5) times – 18 (19, 21, 22) sts. Work even until armhole measures same as for back above bound-off underarm sts, ending with a WS row. Bind off at arm edge 6 (6, 7, 7) sts twice, then 6 (7, 7, 8) sts once.

## BODY EDGING

Sew shoulder seams. Place 1 marker at each front neck corner st, 1 at each lower front corner st and 1 at lower center back st – 5 markers. Beg at center back neck with CC, pick up and knit 1 st in each bound-off or cast-on st and 3 sts for every 4 rows around entire body opening, working M1 at each marker. You will need 2 circular needles to hold all the sts. Work 3 rnds of braid as for sleeves.

## ASSEMBLY

Block. Sew sleeves into armholes, matching underarm markers to center of bound-off body underarm sts. 

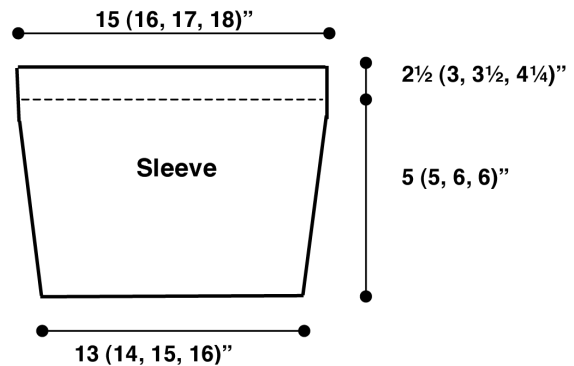
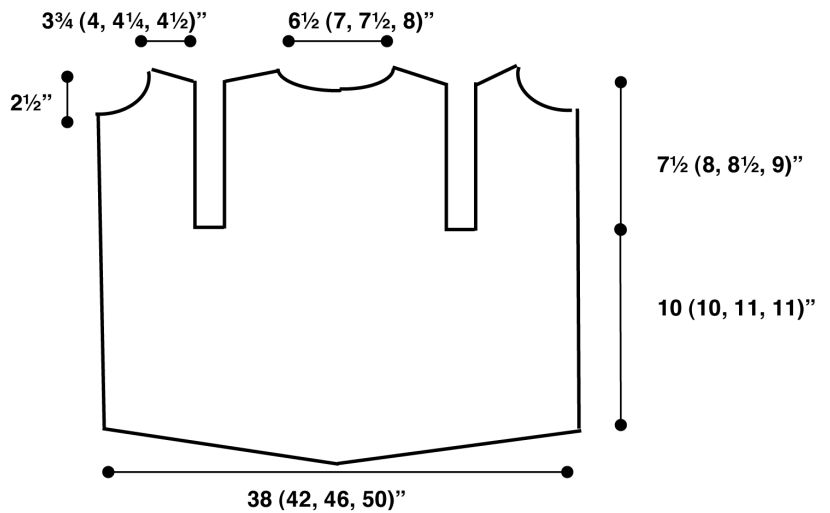

**Picking up for Bound-off Braid**